

Technical Specifications

Mydrain **Micro Line 80**

X683WH MICRO LINE 80 **WHITE** POWDER COATED



Mydrain **Micro Line 80** / Technical Specifications

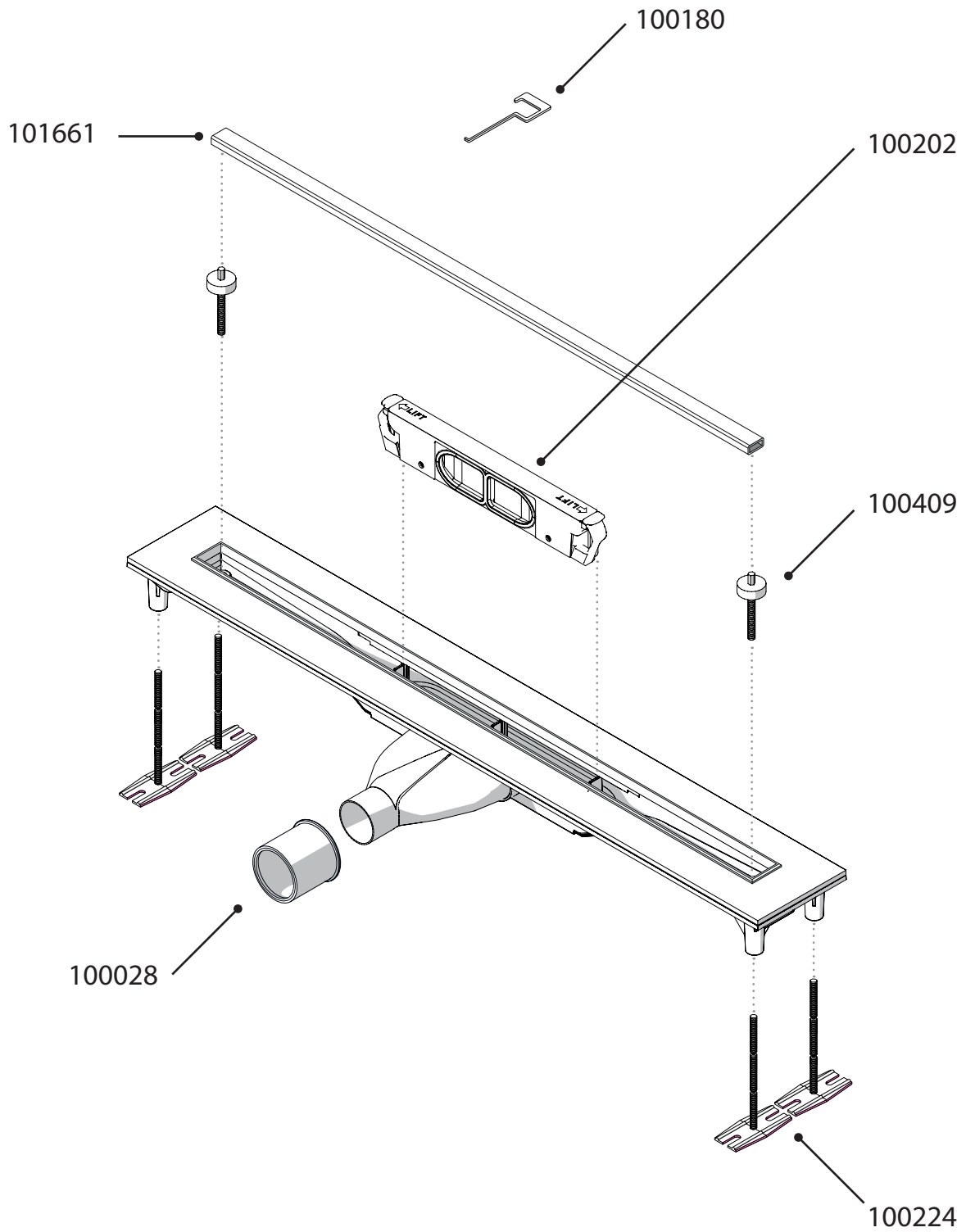

Mydrain **Micro Line 80** / Technical Specifications

80

Box length	935 mm
Box width	235 mm
Box height	90 mm
Weight per box (=complete package)	3,50 kg
Weight per pallet incl. pallet	180 kg
Number of sets per box	1
Number of boxes per pallet	50

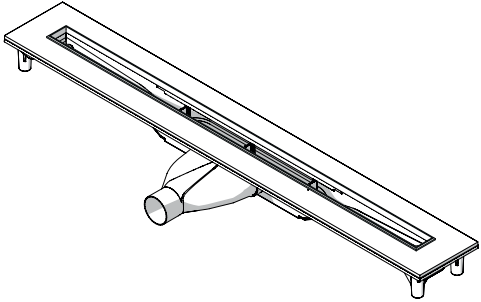
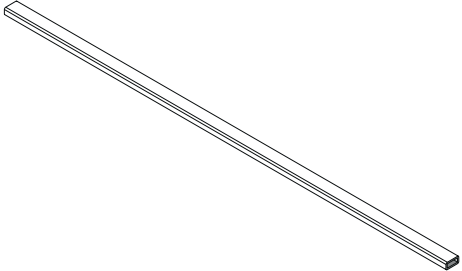
PART	DESCRIPTION	CODE
	<p>MICRO LINE BODY</p> <p>Material : High Heat ABS + Solid Surface Kerrock Dimensions : see later in this technical datasheet General : drainage system with patented "superf" technology drainage capacity: see KIWA table max. water temperature = 90°C</p>	
	<p>GRATE MICRO LINE</p> <p>Dimensions : L 790 mm x W 20 mm x H 10 mm Material : GRILLE MICRO LINE 80 WHITE stainless steel 304 + powder coating</p>	101661

Mydrain **Micro Line 80** / Technical Specifications

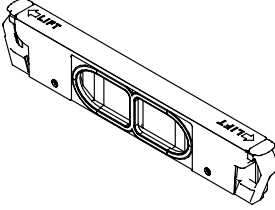
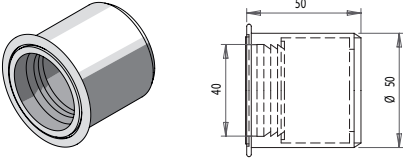
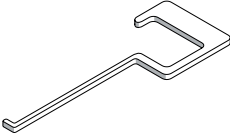
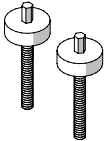
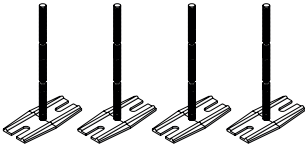
PART	DESCRIPTION	CODE
	<p>SIPHON 100202</p> <p>Material : High Heat ABS + TPE Dimensions : water seal height = 30 mm General : drainage capacity: see KIWA table, not frost resistant</p>	100202
	<p>SLIDING SOCKET 40/50 100028</p> <p>Material : PP-Block Copolymere (PP-B), rubber seal Dimensions : diameter from 40 mm to 50 mm</p>	100028
	<p>MULTI-KEY 100180</p> <p>Material : stainless steel 304 Dimensions : L 85 mm x W 30 mm x H 2 mm</p>	100180
	<p>ADJUSTING SCREW SET 100409</p> <p>Material : set of 2 ABS adjusting screws M6 Dimensions : H 54 x D 20 mm</p>	100409
	<p>FEET SET 100224</p> <p>Material : set of 4 ABS feet Dimensions : L 70 mm x W 33 mm x H 92 mm</p>	100224

Mydrain **Micro Line 80** / Technical Specifications

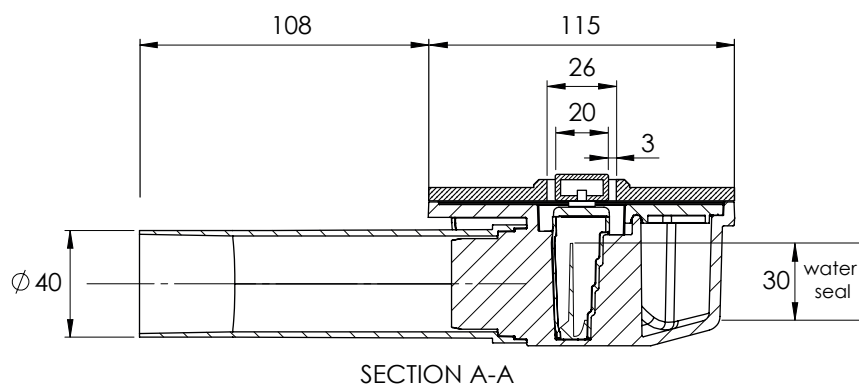
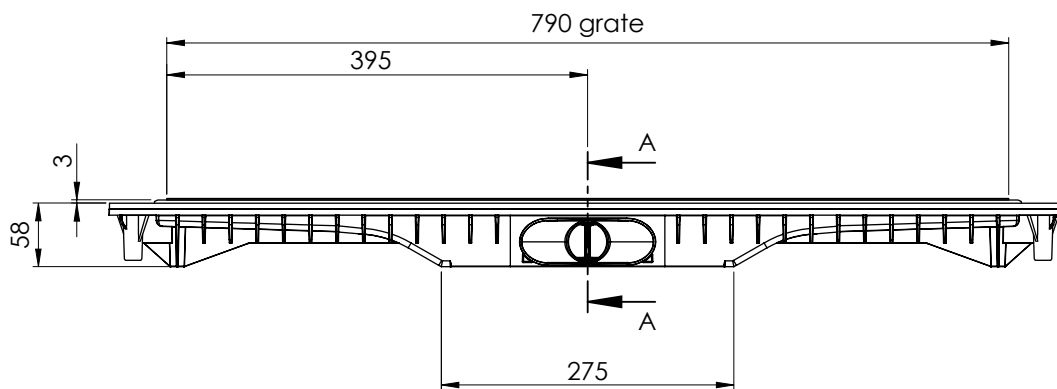
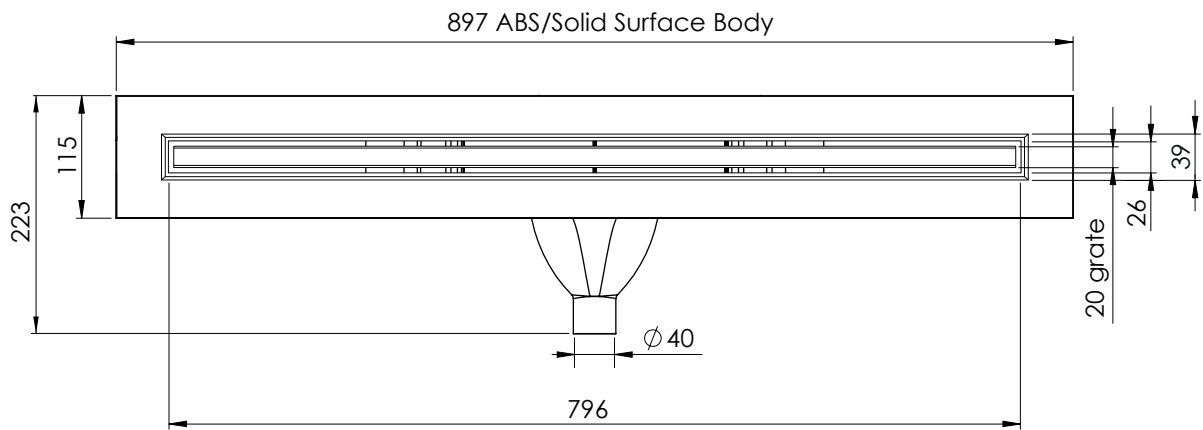

Mydrain **Micro Line 80** / Drainage Rates



	EN 1253-1	EN 274
	<p>This testing method requires a 100 cm drainage pipe and a 20mm water column above the drainage grate.</p> <p>20mm 100cm</p>	<p>This testing method requires a 30 cm drainage pipe and a 120mm water column above the drainage grate.</p> <p>120mm 30cm</p>
	<p>30,8 l/min. =0,51l/sec.</p>	<p>53,3 l/min. =0,89l/sec.</p>
	<p>28,3 l/min. =0,47l/sec.</p>	<p>46,7 l/min. =0,78l/sec.</p>

FLOW CHART

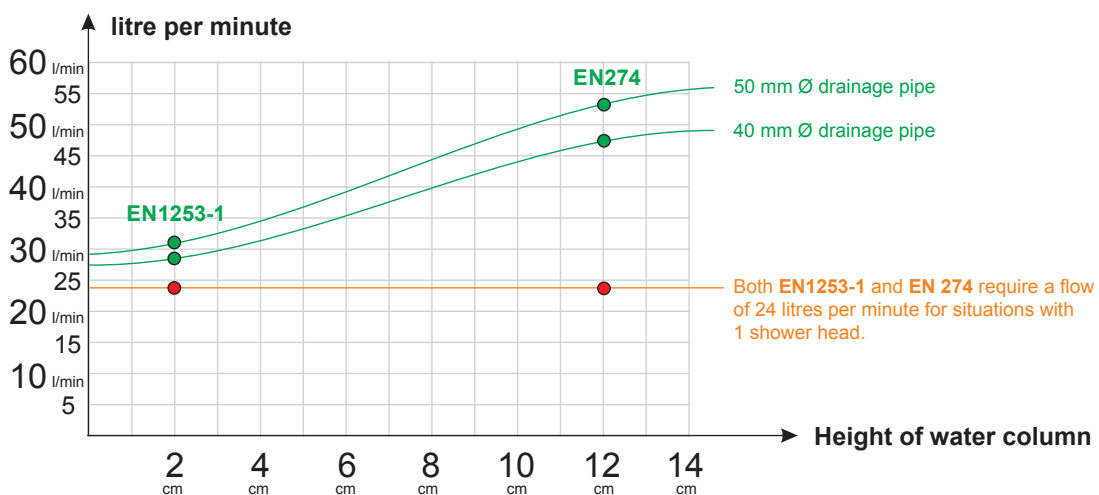

January 2016
Report no.